



**MITSUBISHI
ELECTRIC**

PHOTOVOLTAIC MODULES

Changes for the Better

Best Performance
with Long Reliability

Mitsubishi Electric – A worldwide leader in photovoltaic power generation systems



Our photovoltaic-generation technology originates from our research on Photovoltaic cells for satellites, which started back in 1974.

In combination with our vast experience and accumulated know-how of power systems and semi-conductor technology, we have developed photovoltaic systems designed for superior performance and unbeatable reliability. In addition, Mitsubishi Electric is a pioneer in the photovoltaic inverter industry, commencing research and development in 1981.

At Mitsubishi Electric, we integrate all of our photovoltaic product development and manufacturing operations at our own facilities in Japan. From cell research and production to the manufacturing of modules and inverters, we are able to take control in each step of the process. We are fully confident of the highest quality of our products, and we invite you to enjoy peace of mind for years to come with Mitsubishi Electric Photovoltaic Systems.



1974 Began research and development of photovoltaic technology.

1976 Established a space-satellite business.

1981 Commenced joint research on industrial-use photovoltaic inverters with New Energy and Industrial Technology Development Organization (NEDO) and on electric power utilities.

1985 Delivered high-capacity inverters (two 400kW inverters and one 200kW inverter) to Saijo City, Ehime prefecture, which continue to operate, even decades later.

1987 Commenced research on residential-use photovoltaic inverters.

1996 Began production and sales of residential-use inverters.

1998 Established a PV plant at Iida, Japan and began production of cells and modules.

1999 Awarded a Good Design Award for (BIPV) roof-integrated type modules.

2001 Awarded the 6th New Energy Award for residential hip-roof systems.

2003 Began the production of "lead-free solder" modules.

2008 Achieved the world record for polycrystalline cell efficiency of 18.6 %.

2010 Achieved another world record for polycrystalline cell efficiency at 19.3 % (Measured by the National Institute of Advanced Industrial Science and Technology).

Mitsubishi Electric PV Modules

Over the last 35 years Mitsubishi Electric has accumulated significant photovoltaic experience and knowledge based on our principle of research and development. Also, using our unique strengths as a leading manufacturer of electrical products, we have developed photovoltaic modules with exceptional performance and reliability.

This is "Mitsubishi Electric Quality".

Glass



NEW

Photovoltaic Cells



Increasing the bus bars from 2 to 4 improved cell output by 3%.

EVA



Backfilm

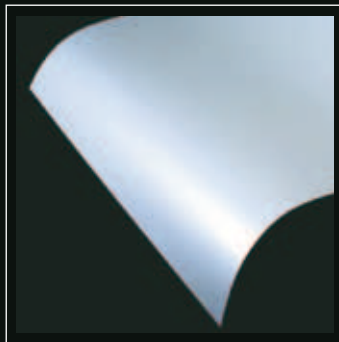

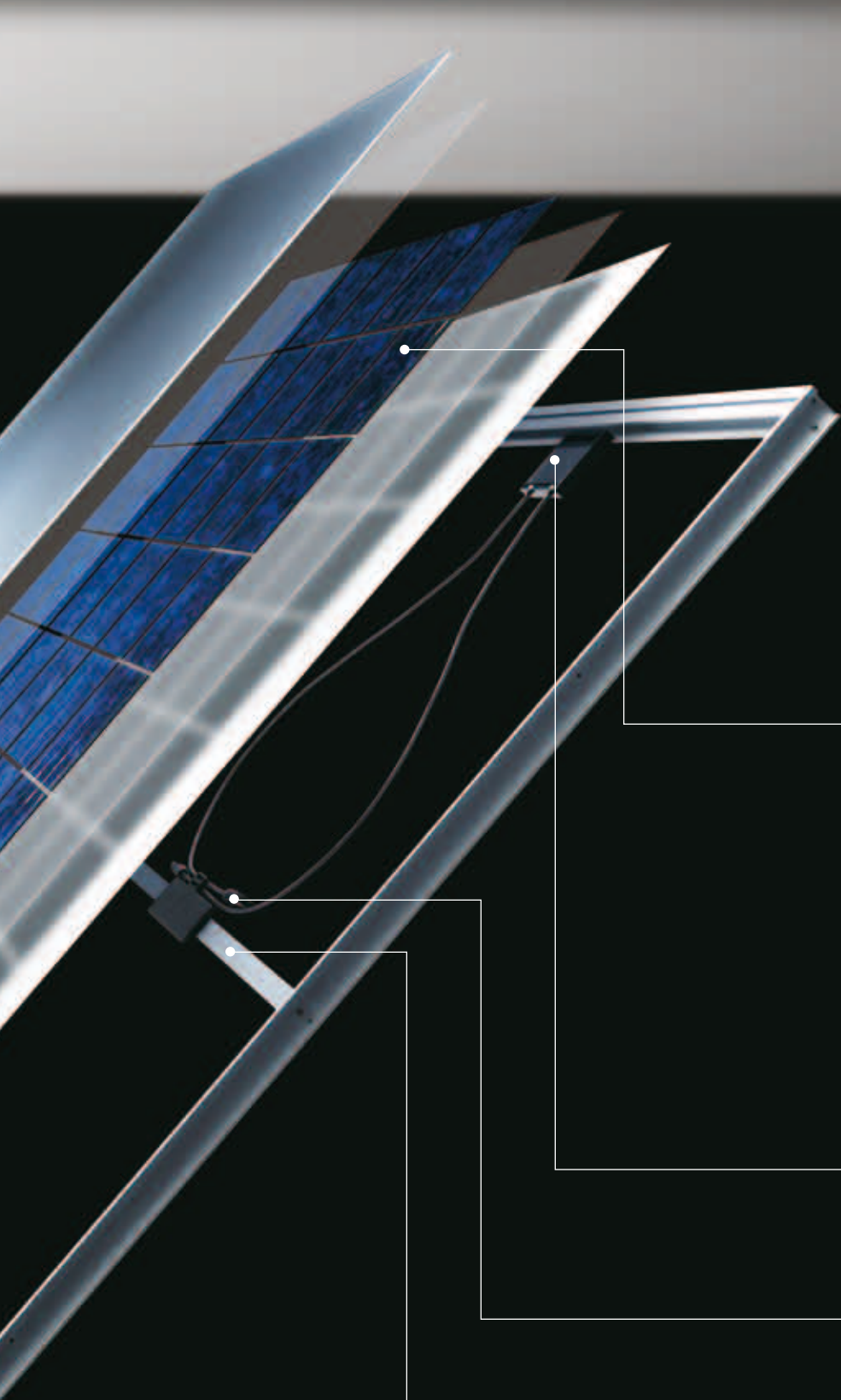

NEW

**Mitsubishi Electric
Logo Insert**



NEW

Junction Box



The junction box has been newly redesigned for even greater safety.

NEW

Aluminium Frame



Stronger I-frame design with protection bar allows module of this size to pass IEC61215 static loading test at 5400 Pa.

Protection Bar



MC4 Connector



High Performance

Higher Cell Efficiency

NEW

4 Busbar Cell

Though an industry-leading innovation of integrating four busbars into each cell, internal electrical resistance is reduced, boosting cell output, by 3 %. Because the distance between bus bars are shorter, the flow of electricity faces less resistance along the electrodes.

Two busbar



Four busbar



Arrows signify flow of electric

Solder-coatingless cells

Our manufacturing process allows us to produce cells that require no solder coating on the electrodes. The uniform light reflection off the electrode surface also contributes to high cell efficiency.

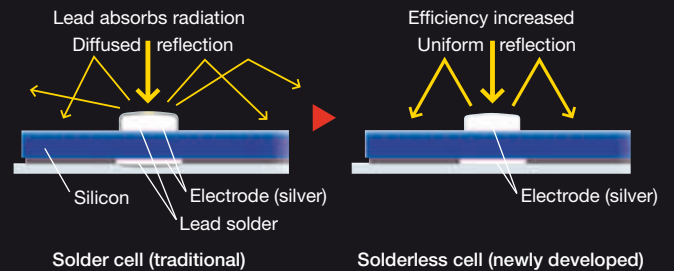

NEW

Thinner Tab Strings

Also the number of tab strings have increased from two to four, the widths of the tap strings have been narrowed, thereby allowing the same surface area exposed to light.

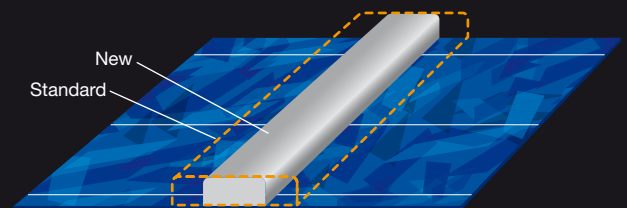

Fine-grid Electrodes

Using our advanced cell-manufacturing processes, we have achieved the ability to print extremely fine electrodes on the cell. As a result, more of the cell surface is exposed to light.

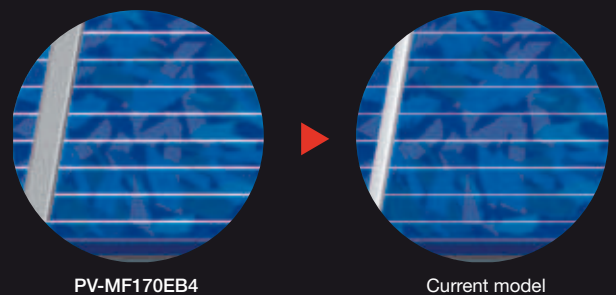

Higher Module Output

NEW

10 x 6 Cell Array

A new 60 cell array design has been implemented in order to achieve a higher output per module, resulting in benefits such as installation cost savings.

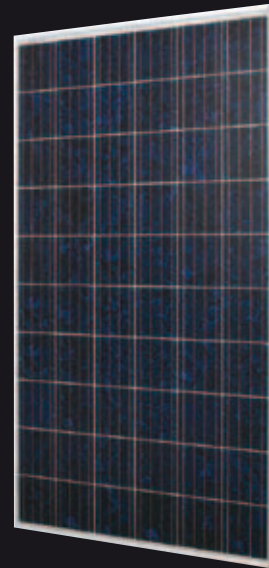

Highly Reflective Back Film

Use of a highly reflective back film in combination with a cell pitch allows more light to be reflected onto the cells, contributing to higher efficiency.

The backfilm is also designed to be a highly effective moisture barrier for long lifetime protection.

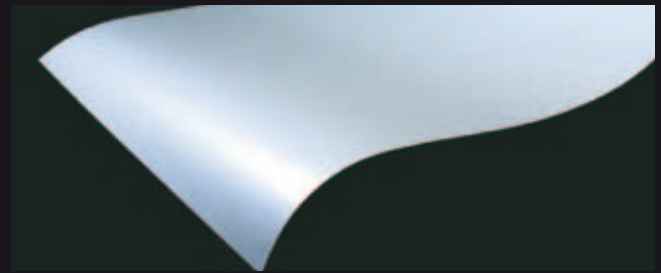

Cerium-free High-transparency Glass

Our modules utilize high-transparency, cerium-free glass to achieve high efficiency and uncompromising strength.



Tight Tolerance

Mitsubishi Electric's state-of-the-art production management system ensures one of the tightest tolerances, in the industry, +/- 3 %. High "real-world" output of PV systems is achieved by reducing module mismatching loss.



High Power in Actual Use

Each module is measured for electrical characteristics then paired together automatically by a sorter. Modules with matching characteristics are paired so that factory-shipment test values actually exceed the nominal output power for each carton. (2 pcs. Per carton)



Extreme Reliability

NEW

New I-frame Design/Protection Bar

Building upon our already track-proven standard frame, the newly refined I-frame boasts a increase in strength by approximately twofold.

The protection bar enhances the structural strength of the module, thereby enabling it to endure extreme environmental conditions.

The new I-frame with protection bar allows even the larger sized module to pass the IEC 61215 static loading test at 5400 Pa.

It easily passes the impact test in which a 545 g (1.18 lb) steel ball is dropped on to the module from a height of 1.295 m (51 in).

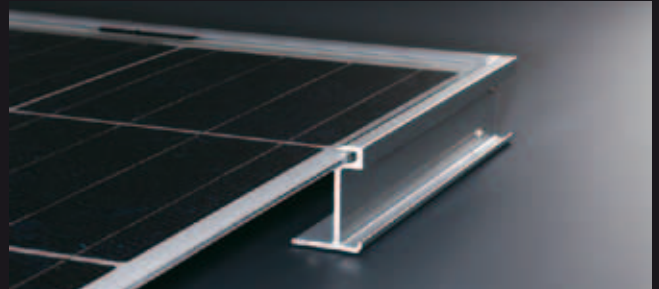

Double Corrosion-resistant Coating

The highly durable aluminium frame is treated with two separate corrosion-resistant coatings for ultimate durability under the harshest conditions. Even the individual screws have double anti-corrosive coatings for strong protection.



Reduced Frame Edge Slope

The slope-angle of the frame edge has been reduced to prevent dust from accumulating and covering the cells.

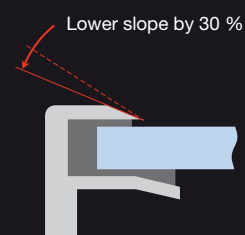

NEW

4 Busbar cell Stress Resistance

The increased number of Busbars per cell enable a more uniform dispersion of stress on the tab. As a result, cells are more durable than before.

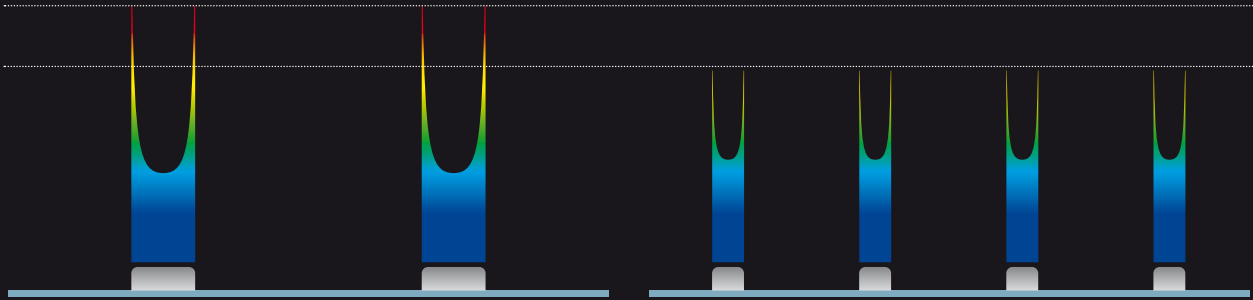

*Graph shows the distribution peaks of stress on the cell.

NEW

Bus Alignment

New graphic-imaging technology has been introduced for aligning cells during the manufacturing process. Bus tabs are connected with more precision than ever before, thereby ensuring an overall increase in reliability and that no faulty connections are made.

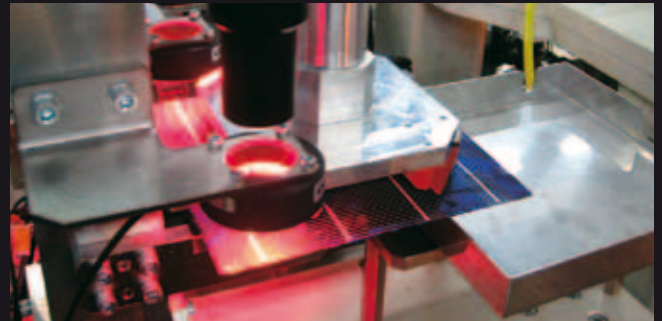

Cell Uniformity

The cells used in our modules go through a strict selection process to ensure that they have the same electrical characteristics. This is important for the overall performance of the modules and preventing the occurrence of “hot spots”.

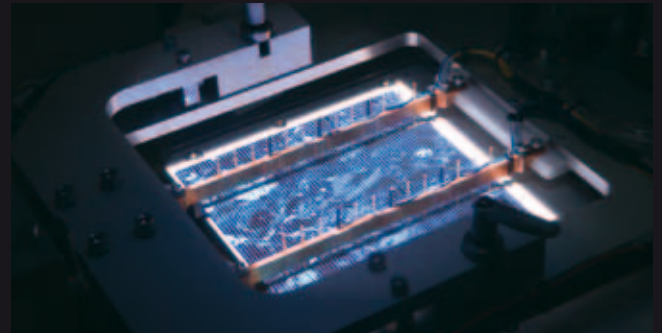

NEW

Straight Tabs and New Flexible Thread

To minimize the stress on inter-cell connections, a large cell pitch in combination with straight tab wiring has been used in the module design.

In addition, a new flexible tab material has been developed to prevent the physical bowing of the cell under thermal stress.

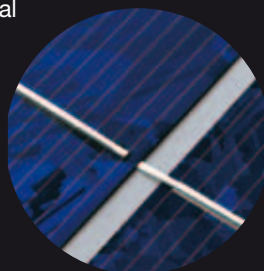

PV-MF170EB4

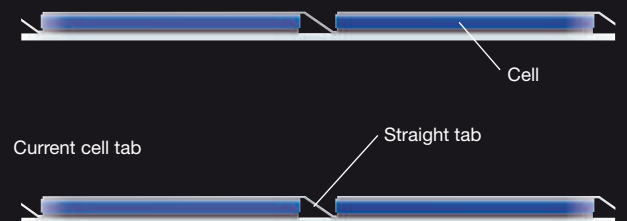

Enhanced Safety

Improved Junction Box

NEW

Multi-layer Protection

The junction is one of the most critical parts of a module in terms of safety. Safety was given the number one priority when designing our junction box. Newly redesigned junction box features multiple layers of protection against water and other risks.

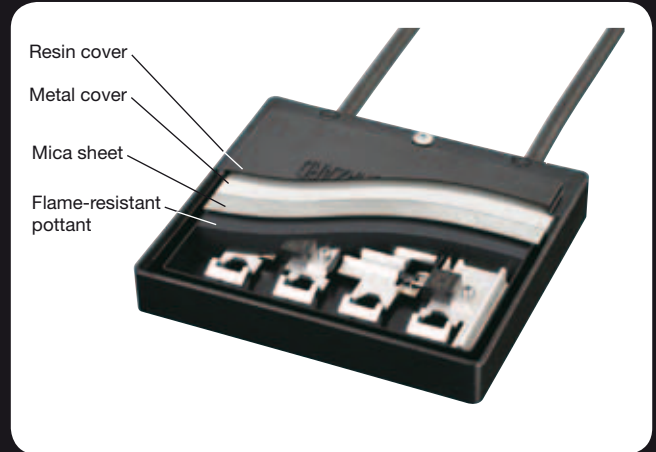

NEW

Improved Heatsink

An original Mitsubishi Electric design, the heatsink spreads heat evenly over a large surface to allow quick dissipation from the junction box and away from the module.

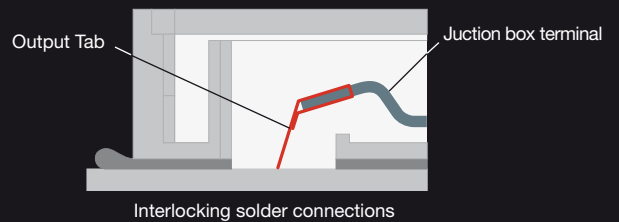

Interlocking Solder Connections

The connection wires within the junction box are entwined together before being soldered to ensure highly secure electrical connections.



Protection Plate

The protection plate cushions the backfilm from direct physical contact with the aluminium protection bar. The plate not only protects the backfilm from physical damage, but also leaves space for water drainage.

MC4 Locking Safety Connectors

The standard locking safety connectors on every module ensure simpler and more reliable installation work.



Multi-Contact PV-KST4/II, PV-KBT4/II

Easier Installation

NEW

Protection Plate with Cable Clip

Cable clips have been conveniently built into the protection plate, thereby eliminating the need for securing tape. The cables can be quickly attached and detached, helping make installation smoother. It reduces on-site waste for an even more eco-friendly product.

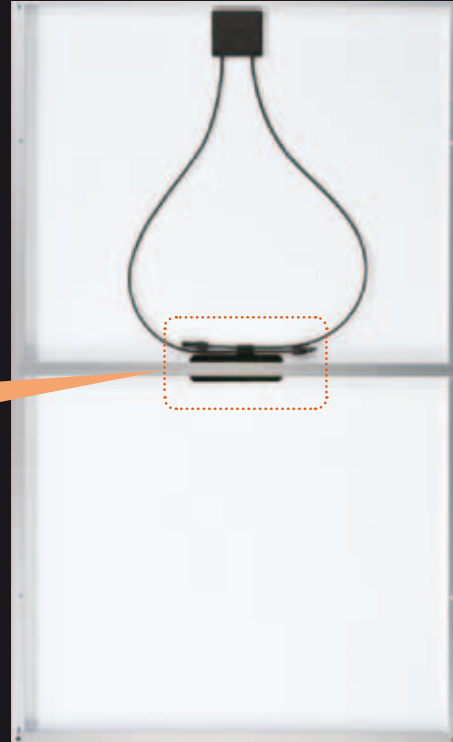

NEW

Easier Handling

The new I-frame has grooves for gripping, enabling easier handling of the module. It is especially convenient when stacking multiple modules at the installation site, or when lifting the module from a flat surface such as the ground.



NEW

Smoother Frame Edges

The new I-frame has been meticulously designed down to the smallest details. For example, the frame features noticeably rounder edges that fit more comfortably to hands. As a result, the module is easier to pick up and hold for better handling.



PV-UD/TD series frame



I-frame

Ecological

Lead-free Solder

Mitsubishi Electric was the first Japanese company to mass produce lead-free solder modules, making our modules even friendlier to the environment.

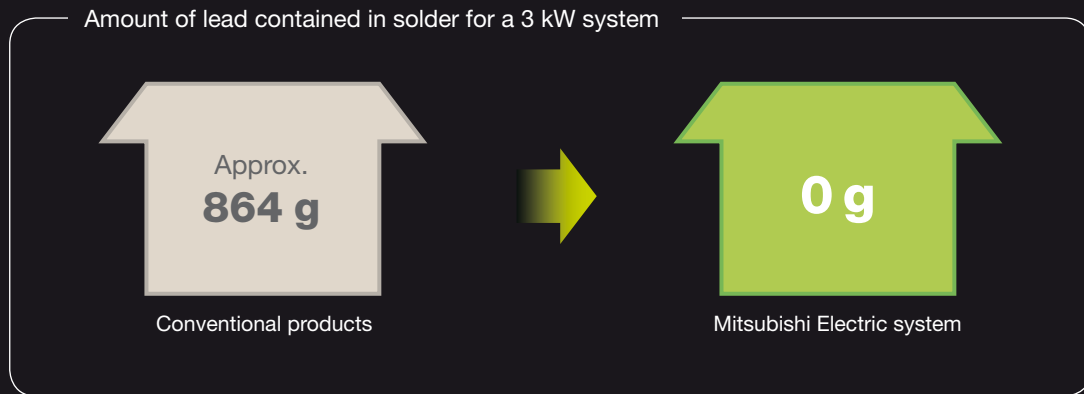

*When using 24 modules of 40-cell type in a system

ISO 14001 Certified Factory

Our factory is managed using comprehensive water conservation and recycling measures in order to minimize the impact on the environment.

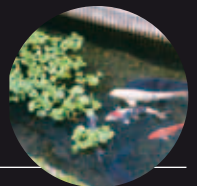

Factory facilities are equipped with our PV systems.



Waste paper and other materials are collected and separated for recycling.



Dozens of apple trees line the factory grounds, providing delicious apples in the fall.

Ecological Logistics

Mitsubishi Electric Modules are shipped on recyclable steel pallets instead of standard wood pallets.



Model Naming Code



Kyoto Factory



Iida Factory



Nakatsugawa Works

Mitsubishi Electric photovoltaic cells, modules, and inverters are proudly produced under strict quality standards at our own factories located in Japan.

Model Naming Code

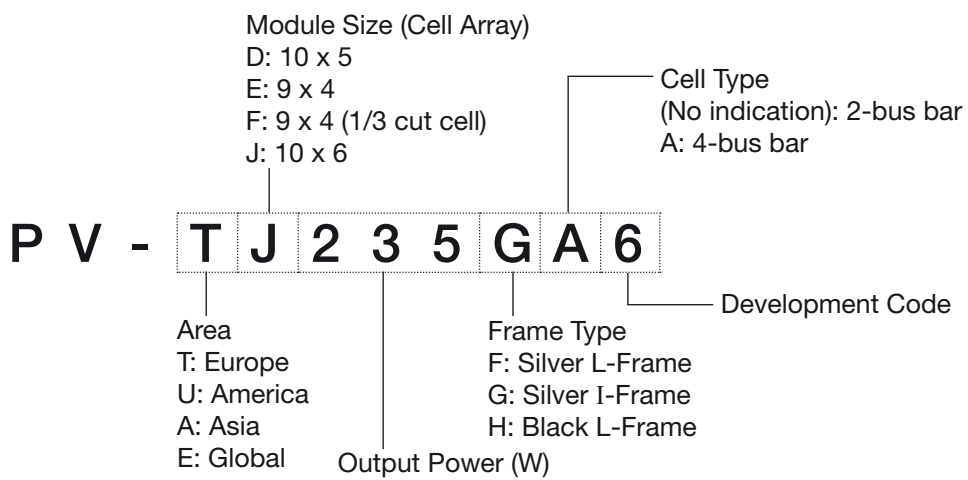

Mitsubishi Electric's Photovoltaic Systems Around

Europe

Austria (400 kW system)



Small power plant

Holland (15 kW system)



Office

Switzerland (23 kW system)



School

Germany (3 kW system)



Private residence

Italy (420 kW system)



Small power plant

Spain (75 kW system)



Hotel

Southeast Asia

Cambodia (3.5 kW system)



Junior High school

Thailand (3 kW system)



Private residence

Papua New Guinea (480 W) system



Private residence (rural home system)

East Asia

Tibet (50 kW system)



Small power plant

China (30 kW system)



Small power plant

Korea (3 kW system)



Private residence

the Globe

Germany (5 kW system)



Private residence

Italy (14 kW system)



School

Italy (50 kW system)



Hotel

USA

USA (1.9 MW system)



Agricultural farm

USA (2 kW system)



Private residence

USA (1.3 MW system)



Brewery

Philippines (440 W system)



Village hall

Indonesia (13 kW system)



Remote telecommunications base station

Singapore (1 kW system)



Public restrooms

Japan (200 kW system)



Platform

Japan (8 kW system)



Private residence

Japan (200 kW system)



Street light



 **MITSUBISHI ELECTRIC CORPORATION**

Mitsubishi Electric Europe B.V.
Photovoltaic Division
Gothaer Str. 8
D-40880 Ratingen
Phone: +49 (0) 2102 486 1593
Fax: +49 (0) 2102 486 1537
E-Mail: info@mitsubishi-pv.de

Your dealer is: